

## REQUEST FOR PROPOSAL

Town of North Hempstead Community Development Agency

### SUPPLY & INSTALLATION OF EXTERIOR STOREFRONT LIGHTING FOR PRIVATE COMMERCIAL BUILDINGS

Issued Date: November 19, 2024

Due Date and Time: 2:30pm Friday, November. 29, 2024

#### 1. INTRODUCTION:

The Town of North Hempstead Community Development Agency (“TNHCDA”) is conducting a storefront improvement program to assist private commercial building owners. This Request for Proposal (RFP) is specifically for quotes for work to be expedited on Westbury Avenue, Carle Place, NY. The TNHCDA engaged Vision Accomplished (“VA”) to administer the program and now seeks your proposal for items as referenced below. This RFP does not seek quotes from a general contractor who will subcontract particular trades. Rather, we request proposals from trade professionals to form a contract directly with the TNHCDA. The contract will require your responsiveness to project schedules, needs of property owners and coordination with other assigned trade professionals and contractors.

Upon agreement with qualified building owners, TNHCDA will order and pay for approved professional crafting and installation of specific storefront improvements. The focal point is to harmoniously improve aesthetics with quality signs, lights and/or awnings in this business district.

We seek your proposal to supply and install, new/approved exterior storefront lighting fixtures, as directed, in a timely manner on specific commercial storefronts. Municipal requirements, permits, insurance and public policies apply so please note your experience. If awarded, you contract with TNHCDA to perform services on one or more buildings, as assigned. This may lead to the potential continuation of orders to follow, contingent on satisfactory performance and available funding. This contract is not exclusive so based on planning, need for expediency and other considerations, the TNHCDA will likely award more than one professional contract for on call assignments, as needed. If mutually agreed upon, the TNHCDA may award work on other projects as well.

The TNHCDA intends to select the most favorable offers and needs to begin approved projects speedily to fully conclude the project by mid-February 2025. The TNHCDA expects that, upon notice of your award, you will acquire all known necessary materials and supplies needed for delivery with knowledge that your installation of approved façade improvements is expected to commence and continue, as weather permits, from as early as this December through February 2025.

#### 2. INFORMATION FOR PROPOSERS:

Here is how this project and proposal works: You submit pricing on standard materials and sizes, as requested. Unless stated otherwise, equipment is specified. So, while it may be possible, not probable, to later substitute (with written approval) your proposal should not now substitute. If you cannot supply what is specified, indicate the same and skip that portion of your quotation. If any line is blank, we will insert the highest price quoted by another for that line in your proposal, plus 5% contingency.

For purposes of this proposal and to enable work to begin shortly, we provide “Exhibit C” *sample conceptual* renderings of some anticipated storefront renewals. Once ready, the TNHCDA will acquire permission from building owners to commence work thereon. Be advised that while these building owners & tenants have expressed desire to participate, required agreements have not yet been formed. *Moreover, the attached sample improvements have not been discussed with applicable building owners and are subject to change. Do not consider these as work orders.*

#### 3. PRE-PROPOSAL SUBMISSION:

- a. Pre-Register for proposal: Register by submitting your statement of interest and contact information to TNHCDA at [CDADepartment@NorthHempsteadny.gov](mailto:CDADepartment@NorthHempsteadny.gov) and copy VA at [visionaccomplished@fastmail.com](mailto:visionaccomplished@fastmail.com).
- b. Questions: Submit written questions to TNHCDA at [CDADepartment@townofnorthhempsteadny.gov](mailto:CDADepartment@townofnorthhempsteadny.gov) and copy to VA at [Visionaccomplished@fastmail.com](mailto:Visionaccomplished@fastmail.com). You may also phone Tom Savino of Vision Accomplished at (516) 622-9680.
- c. Addenda: for this RFP if any, will be available on the TNHCDA website at <https://www.northhempsteadny.gov/CDA-RFPs>. Those interested in this RFP are expected to check the website for updates or addenda and submit proposals accordingly.

#### 4. PROPOSAL SUBMISSION:

To be considered for this program submit to TNHCD and VA at minimum, the following information and documentation:

- a) Company Information: On letter head or equal in a few sentences, or by way of premade marketing material, website, or social media link let us know why your company is qualified to provide the services sought in this RFP. If you prefer, you can fill out our [TNCCDA Contractor Prequalification Application](#). You are welcome to submit pictures or samples of your work.
- b) Town Sign Erectors License: To install an lighting you must have or apply for a Town Sign Erectors license. Click here for further information [Town of North Hempstead Sign Erector's License](#). Please advise of your status as a Town Sign Erector or intention/proof of application.
- c) Submit and complete Appendix A: This includes 1. Statement of Understanding, Disclosure Form, and Non-Collusive Proposal Certification.
- d) Pricing: Submit complete copy of this RFP along with "Contractor **PRICING SHEET** Exhibit B" of this RFP.
- e) Date and Time for Submitting your Proposal: We are accepting proposals on an ongoing basis. However, we intend to award initial contracts and will review submissions based on proposals submitted on or before November 29, 2024 at 2:30 pm.

Please submit your RFP package via email with the title **Supply and Install Exterior Storefront Façade Lightings** to [CDADepartment@northhempsteadny.gov](mailto:CDADepartment@northhempsteadny.gov) with a copy to [visionaccomplished@fastmail.com](mailto:visionaccomplished@fastmail.com).

**Or**

You may submit 2 copies of your proposal to: Town of North Hempstead Community Development Agency, 51 Orchard Street Roslyn Heights, NY 11577-1326.

- f) Submitting a TNHCD Prequalification Application: The TNHCD is receiving applications on an ongoing basis, so a specific date and time for submitting a Prequalification Application is not required. But don't wait. Several new projects will be coming online soon, and we look forward to forging new partnerships.

#### 5. EVALUATION OF PROPOSALS:

TNHCD and VA will evaluate each proposal with emphasis on the following factors:

- a) Demonstrated successful, relevant experience on other projects of comparable value and scope.
- b) Accessibility to project areas and availability to expedite services.

#### 6. RIGHT OF REJECTION BY TNHCD:

TNHCD and VA reserves the right to select respondents to this RFP who best meet the requirements of the RFP. TNHCD and VA reserve the right, for any or no reason and in its sole and absolute discretion, to (1) amend, in whole or part, this RFP, (2) withdraw or cancel this RFP, (3) accept any or all bids in whole or in part, (4) award agreements to one or more than one respondent, and (5) accept or reject any or all bids prior to or after opening proposals for any or no reason and with no penalty to the TNHCD.

#### 7. NOTICE OF AWARD:

A selected contractor will be notified they have been selected by digital notice or in writing. Neither the Contractor's approval nor the issuance of notice shall constitute a binding commitment to enter a contract with a Contractor, as any binding arrangement must be through a negotiated and fully executed contract ("Contract") with the TNHCD. After a Contract is fully executed, the TNHCD or VA will assign work through Work Orders approved by TNHCD as funder.

**EXHIBIT A**  
**ORGANIZATION QUALIFICATION STATEMENT**

The Organization's Qualifications Statement consists of the following documents:

1. Statement of Understanding
2. Disclosure Form
3. Non-collusive Proposal Certification

Please complete ALL THREE forms and submit them with the Proposal.

THE AGENCY RETAINS THE ABSOLUTE RIGHT TO REJECT ANY PROPOSAL THAT FAILS TO INCLUDE COMPLETE AND ACCURATE ORIGINALS OF ALL FORMS

**STATEMENT OF UNDERSTANDING**

By signing in the space provided below, the undersigned certifies, under penalty of perjury, as follows:

1. I am duly authorized to submit this Proposal on behalf of the below-listed sole proprietorship/company/partnership /corporation.
2. That he/she has read and understands all terms and conditions under this RFP.
3. That he/she can and will abide by all terms and conditions under this RFP.
4. That he/she agrees to accept payment per the requirements of the RFP and
5. That he/she agrees that the Proposal submitted to the Agency shall be irrevocable and that he/she will if his/her Proposal is accepted, enter into an agreement with the Agency under the terms and conditions set forth in the RFP.
6. That he/she certifies that his/her Organization will carry all types of insurance specified in the agreement.

The undersigned further stipulates that this Proposal's information is true and accurate to the best of his/her knowledge.

\_\_\_\_\_  
Signature

\_\_\_\_\_  
Name of Organization

\_\_\_\_\_  
Title of Person Signing

## DISCLOSURE FORM

*The signing of this questionnaire certifies under oath the truth and correctness of all Statements and all answers to interrogatories hereinafter made.*

Provide answers to each of the following questions and supporting documentation, where necessary:

1. **Adverse Equal Opportunity Determinations:** Identify all adverse determinations against your Company/Corporation/Partnership, or its employees or persons acting on its behalf (hereinafter "Organization"), concerning actions, proceedings, claims, or complaints concerning violations of state, federal, or municipal equal opportunity laws or regulations.
  
2. **Convictions and Unscrupulous Practice:** Has your Organization, or any of its employees present or past, or anyone acting on its behalf, ever been cited for unscrupulous practice or been convicted of any crime or offense arising directly or indirectly from the conduct of your Company/Corporation/Partnership's business, or has any of your Organization's officers, director or persons exercising substantial policy discretion ever been convicted of any crime or offense involving business/financial misconduct or fraud? If so, describe the convictions and surrounding circumstances in detail.
  
3. **Pending or Threatened Actions/Suits:** Describe any past or present action, suit, proceeding, or investigation pending or threatened against your Organization, including, without limitation, any proceeding known to be contemplated by government authorities, private parties, or current or former clients.
  
4. **Criminal Misconduct:** Has your Organization, or any of its employees, or anyone acting on its behalf, been indicted or otherwise charged in connection with any criminal matter arising directly or indirectly from the conduct of your Organization's business which is still pending, or has any of the Organization's officers, directors or persons exercising substantial policy discretion been indicted or otherwise charged in connection with any criminal matter involving business or financial misconduct or fraud which is still pending? If so, describe the indictments or charges and surrounding circumstances in detail.
  
5. **Conflicts of Interest:** Disclose any of the following, and describe any procedures your Organization has or would adopt to assure the Agency that a conflict of interest would not exist in the future.
  - a. Any material financial relationships that your Organization or any Organization employee has that may create a conflict of interest or the appearance of a conflict of interest in contracting with or representing the Agency.
  
  - b. Any family relationship that any employee of your Organization has with a member, employee, or official of the Agency that may create a conflict of interest or the appearance of a conflict of interest in contracting with or representing the Agency.

- c. Any other matter that your Organization believes may create a conflict of interest or the appearance of a conflict of interest in contracting with or representing the Agency.

THE AGENCY RETAINS THE ABSOLUTE RIGHT TO REJECT ANY PROPOSAL THAT FAILS TO INCLUDE A COMPLETE DISCLOSURE STATEMENT FORM.

Dated this \_\_\_\_\_, day of \_\_\_\_\_, 20\_\_\_\_\_

\_\_\_\_\_  
(Signature of Individual)

\_\_\_\_\_  
(Print First and Last Name)

\_\_\_\_\_  
(Print Title)

By: \_\_\_\_\_ (Signature)  
(Legal Business Name of Company/Partnership /Corporation)

**NONCOLLUSIVE PROPOSAL CERTIFICATION**

By submission of this Proposal, each Organization and each Person signing on behalf of any Organization certifies, and in the case of a joint proposal, each Party certifies as to its own Organization, under penalty of perjury, that to the best of knowledge and belief:

- (1) The prices in this Proposal were arrived at independently without collusion, consultation, communication, or agreement to restrict competition as to any matter relating to prices with any other Organization or a competitor;
- (2) Unless otherwise required by law, the prices quoted in this proposal have not been knowingly disclosed by the Organization and will not knowingly be disclosed by the Organization before opening, directly or indirectly, to any other Organization or competitor; and
- (3) No attempt has or will be made by the Organization to induce any other person, partnership, or corporation to submit or not to submit a proposal to restrict competition.

I hereby certify under the penalties of perjury that the foregoing Statement is true.

By: \_\_\_\_\_

Signature	Date
_____	_____
Print Name	Title
_____	_____
Legal Name of Individual or Business Name of Company/Partnership/Corporation	Organization's State Tax Identification #
_____	_____
Address	Email Address
_____	_____

Date \_\_\_\_\_

**Exhibit B - PRICING SHEET**  
**Supply and Installation of Custom Wall Lighting**

**A. Prerequisite Standards to Assume For Supply and Install of Lighting as Preparation For Quotes**

Pricing below is to supply, install and service lighting equipment noted, understanding that lighting install will be coordinated to occur soon after new wall signs are installed and prior to installation of façade awnings where the same is also ordered. Placement of sign lights, will be case-by-case based on available space at site and details of custom lettering on sign to be illuminated. Gooseneck sign lights are generally set 6"- 1' above each sign with illumination spread at 2.5' to 3' apart to focus on lettering and logos.

Pricing to include: LED fixtures; an automatic *Dawn-Dusk* activation for each storefront; supply of an electrical box and time clock. Assume average installation with a power source within 10' of location of installation:

**B. Supply and Installation of Custom Sign Lighting**

- |   |  |           |
|---|--|-----------|
| 1 | LED Gooseneck Light #20/12-850 12.25" Diameter Powder Coat Black             | \$ _____; |
| 2 | LED Gooseneck Light #20/850 9.75" Diameter Powder Coat Black                 | \$ _____; |
| 3 | LED Eyebrow Can Downlight <i>Recessed</i> Beneath Exterior Commercial Soffit | \$ _____; |
| 4 | LED Eyebrow Can-less Shallow Downlight <i>Recessed</i>                       | \$ _____; |

**C. Pricing for the Following or Equivalent Exterior Storefront Wall Sconce:**

- |   |   |           |
|---|---|-----------|
| 1 | Canterbury Exterior Downlight - Early American Sconce Black Die-Cast Aluminum | \$ _____; |
| 2 | NUVO 60-3469 Exterior Die-Cast Aluminum Sconce Light                          | \$ _____; |

**D. Pricing for Electrical Installation Supplies & Services:**

- |     |   |           |
|-----|---|-----------|
| i   | Price per foot to supply and install <b>additional</b> circuit wiring as needed | \$ _____; |
| ii  | Pricing per extra <b>additional</b> electrical box installed if needed          | \$ _____; |
| iii | Per <b>additional</b> time clock if needed                                      | \$ _____; |
| iv  | Pitch Pocket if needed  | \$ _____; |
| v   | Installation Cost Per Sign Light  | \$ _____; |
| vi  | Installation Cost Per Eyebrow Can Light   | \$ _____; |
| vii | Installation Cost Per Wall Sconce   | \$ _____. |

Please specify all items that you want to consider, not in the form requested above:

---

---

---

Please confirm specific equipment above will be used or note any item not proposed precisely in the form or manner requested:

\_\_\_ ("Yes" if confirmed) or note changes: \_\_\_\_\_;

Provide period of guarantee/warranty with minimum three years for workmanship and ten years for equipment. \_\_\_\_\_;

Note that along with an approved work order for specifics, you will be guided by either an artistic rendering that depicts the particular recommended façade improvement, without elevations. Or you will see a similarly sized/situated storefront that will guide you to replicate lighting with different storefront exterior dimensions or features. You must measure and set proper elevation for the location's lighting while considering coordination and placement consistent with other installations of signs and awnings. Sign lighting generally anticipated to spread illumination slightly beyond all words or images in the sign below. Coordination of trade schedules will be conducted through *Vision Accomplished* or TNHCDCA.



# Lighting

Westbury Avenue has a more active retail character to the east and a more business-oriented character to the west. Therefore, these lighting options suggest two design approaches: historic/traditional and contemporary design. Either could be used for part or the whole length of Westbury Avenue.

Additionally, sign lighting may be eye-brow can lights installed beneath the soffit where traditional gooseneck lighting cannot be done. Moreover, there may be occasions when the electrician must connect a feed left by a sign-maker on site, to the appropriate electrical power box. Coordination with sign maker and project manager will be necessary if that were to occur. TNHCDCA foresees that if that were to occur, it will be very infrequent. If needed, prior approval from project manager is necessary and a gooseneck light install fee will be allowed.

Traditional Gooseneck



Traditional Sconce



**Gooseneck Sign Light Options - Westbury Ave., Carle Place**

<b>#20/12-850</b>	Lamp: E26 Socket	Finish: 29 Oven Baked	Drawn: CB	Scale: 1/5	Approvals
	Max Wattage: 200 W	Powder Coated Paints	07/2024		
12 1/4" Dia   27" Ext   19 3/4" H	Number of Sockets: 1	Material: Aluminum	Note: All dimensions are nominal. Actual dimensions may vary.		
Shade: #20/12A   Arm: #850	Voltage: 120 V				

Standard powder coated colors **Black**



All aluminum construction for outdoor use.  
LED Fixtures in 3000K and 4000K,  
LED12 = 800 lumens, LED22 = 1800 lumens.  
LEDs 12 & 22 are 120 volt.



<b>#20/850</b>	Lamp: E26 Socket	Finish: 29 Oven Baked	Drawn: CB	Scale: 1/5	Approvals
	Max Wattage: 200 W	Powder Coated Paints	05/2024		
9 3/4" Dia   27" Ext   17 1/4" H	Number of Sockets: 1	Material: Aluminum	Note: All dimensions are nominal. Actual dimensions may vary.		
Shade: #20A   Arm: #850	Voltage: 120 V				

## Lighting

# Canterbury Outdoor Downlight, Black Die-Cast Aluminum

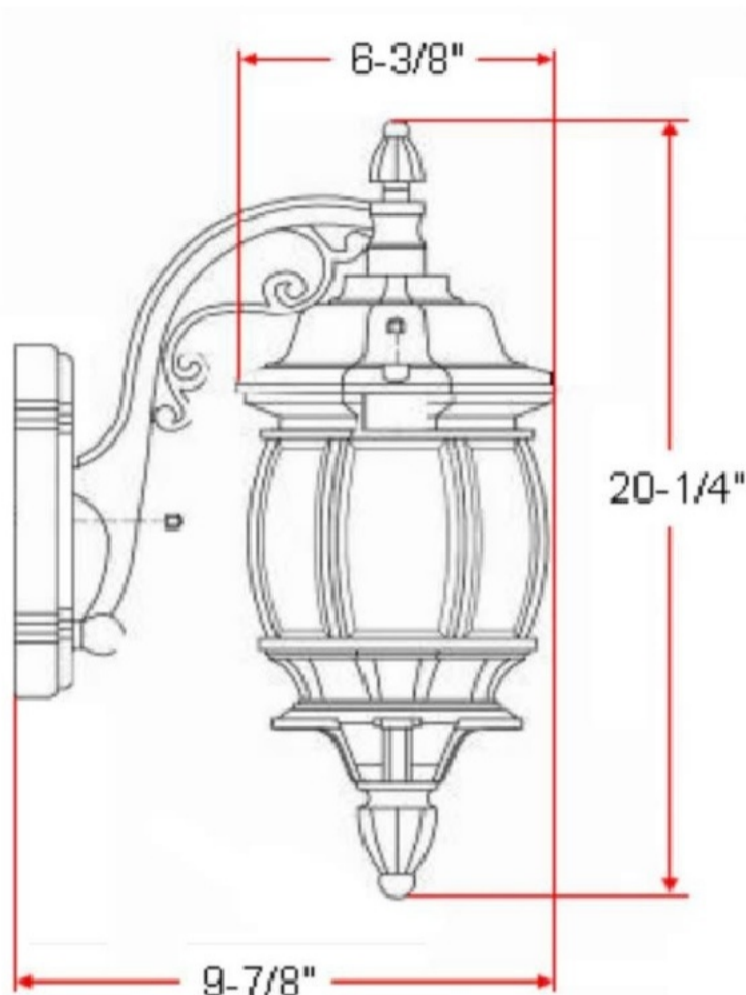

### SPECIFICATIONS

MOUNTING:	Flush Mount
SLOPED CEILING ADAPTABLE:	N/A
LAMP TYPE I:	13.2W LED
BULB INCLUDED:	Yes
WATTS PER BULB:	N/A
TOTAL WATTAGE:	13.2W
DIMMABLE:	No
MATERIAL CONSTRUCTION:	Steel
ASSEMBLED DIMENSIONS:	10.875" L x 6.625" H x 10.875"
WEIGHT:	3.28 lbs.
BACKPLATE DIMENSIONS:	9.37" H x 9.37" W
CANOPY CEILING DIMENSIONS:	N/A
GLASS/SHADE DIMENSIONS:	N/A
GLASS/SHADE MATERIAL:	Glass
GLASS/SHADE TYPE:	Clear
GLASS/SHADE COLOR:	Clear

LED BRIGHTNESS (LUMENS):	528
LED COLOR CORRELATED TEMPERATURE (CCT):	3000K
LED COLOR RENDERING INDEX (CRI):	82
LED EFFICACY:	40
LED AVERAGE RATED LIFE:	50,000 hours
ENERGY EFFICIENT:	Yes
LIGHTING AMPS:	N/A
VOLTAGE:	120V

<b>Features</b>	requires one 100 watts medium base e27 incandescent bulb
<b>Finish</b>	Black
<b>Color</b>	Black
<b>Brand</b>	Design House
<b>Watts</b>	60 Watts
<b>Manufacturer</b>	Design House
<b>Light Bulb Type</b>	LED

WARRANTY:	10-Year limited warranty
UL/ETL CERTIFICATION:	ETL
WET/DRY/DAMP LISTING:	Wet
ADA COMPLIANT:	No
ENERGY STAR CERTIFIED:	No





## NUVO 60-3469

CENTRAL PARK 1 LT OUTDOOR

### General

Status	Active
Collection	Central Park
Finish	Textured Black
Style	Traditional
Number of Lamps	1
Height (in.)	20
Width (in.)	6
Extension (in.)	9.75
Indoor or Outdoor Fixture	Outdoor

### Specifications

Base	Medium
Bulb Type	Incandescent
Max Wattage	100W
Voltage	120V
Bulb Included	No
Glass Description	Clear Beveled
Weight (lb.)	3.53
Fixture Type	Wall Lantern
Fixture Material	Die-cast Aluminum

### Dimensions

Top to Outlet	13
---------------	----

### Compliance

Safety Listing	cULus
Location Rating	Wet
UL Application	Wall
Energy Star	No
DLC Approved	No
ADA Compliant	No
CA T20 / T24 Rationale	T20 Exempt - Fixtures Not Regulated
California Status	Lawful for sale in California
Title 20 / 24 Status	Lawful for sale
California Prop 65	Lead
RoHS Compliant	Yes

### Additional Information

Warranty	1 Year Limited - Fixtures
----------	---------------------------

## Exterior LED Recessed Can Downlight

Qualifications	Assembled in USA (ARRA), IP67, CETL listed
Features	Shatterproof Lens, Vandal-Resistant, Outdoor, Wet-Location Rated
Dimming	Universal and 0-10V dimming drivers
Lumens per foot	100-2499 Lumens
Wattage	25 Watts & Under, 25 to 49 Watts
Voltage	120-277V, 120V
Finish	White, Black, Silver, Bronze
Light Color	2700K, 3000K, 3500K, 4000K, 5000K, 5600K
CRI	80+
Light Direction	Direct Downlight

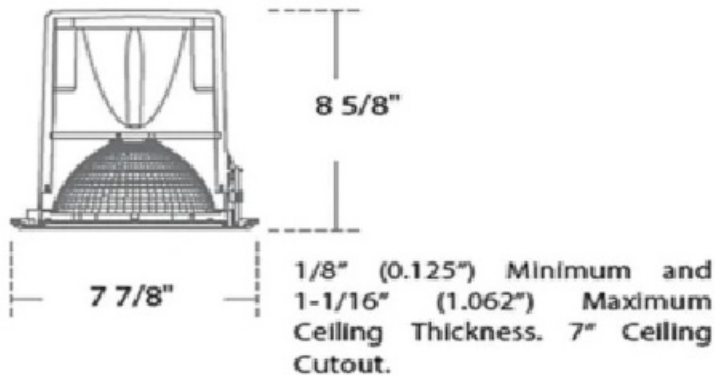

## Exterior LED Canless Shallow Recessed Downlight

Qualifications	cETLus, Title 24, Title 24-JA8
Features	Wet-Location Rated
Dimming	TRIAC
Lumens per foot	600 - 1199 Lumens, 1200 - 2199 Lumens
Wattage	25 Watts & Under
Voltage	120V
Light Color	Color Temperature Select Switch 3000K/4000K/5000K
CRI	90+
Mounting	Recessed Trim Flange
Light Direction	Direct Downlight



Available in  
4", 6" & 8"



90+ CRI

SELECTABLE SWITCH  
3000K/4000K/5000K

650 lumens - 1800 lumens

**Selected  
Goose Neck Sign Lighting for Letters  
LED fixtures**

Repoint and Repaint Existing Brick  
Facade (Paint to Match Existing)  
**(NIC)**

New Awning  
(Sunbrella "Black (8408)")  
**(NIC)**

**Mid-size to small awning  
face profile - 12" or less**

Install front entrance LED  
downlight above doorway  
**(NIC)**

Paint Existing Door  
- Match Building Trim  
**(NIC)**

*Decorative salon image applique  
attached to sign:*



New Sign - Paint to Match  
**Balboa Mist OC-27**

*Pin-Mounted Molded Letters  
Back-lit Halo Sign Letter Lighting*

*Hanging blade sign with custom  
business logo/message*

**Traditional front wall sconce  
LED fixtures**



**SAMPLE DRAFT FOR  
DISCUSSION ONLY**

**(NIC) = Not in Contract being proposed, just shown as reference**

568 Westbury Avenue  
Savoire Faire Salon

VISION ACCOMPLISHED - TOWN OF NORTH HEMPSTEAD  
FACADE IMPROVEMENT PROGRAM

**Install Gooseneck Sign Lights  
LED fixtures**

*Add Fypon/equiv cornice molding cap  
- paint to match lower building (NIC)*

*New Sign - Paint to Match  
Benjamin Moore*

*(NIC) Balboa Mist OC-27  
HDU sign board with painted letters  
Midnight Blue (1638)*

*Repoint and Repaint Existing Brick  
Facade (Paint to Match Existing)  
Midnight Blue (1638) (NIC)*

**COPERPLATE GOTHIC  
BOLD FONT**

*New Awning (Sunbrella (NIC)  
Gravel (4833)"; Midnight Blue  
(1638) Letters;*

**Mid-size to small awning face  
profile - 12" or less.**

*(NIC) Hanging blade sign with custom  
business logo/message*

**COPERPLATE GOTHIC BOLD FONT**

*Install front entrance LED (NIC)  
downlight above doorway*

**Traditional front wall sconce**

*Refurbish/Repaint Existing Door  
Add upper door panel window w/  
frame following existing door (NIC)*

*(NIC)  
Add internal stiles and  
rails into Window System  
for panel effect*



**SAMPLE DRAFT FOR  
DISCUSSION ONLY**

**(NIC) = Not in Contract being proposed, just shown as reference**



**NOTE:** Must first review existing roof line to determine if structure can be boxed out w/ this approach that does not build a new false facade atop

